

## Exhaust System

### Inspection and Verification

1. Verify the customer concern.
2. Visually inspect the components of the exhaust system and related controls that may affect exhaust gas quality or loss of power.
3. Visually inspect for obvious signs of mechanical damage. Refer to the following chart.

### Visual Inspection Chart

Mechanical
<ul style="list-style-type: none"> <li>● Exhaust pipe pinched or crushed</li> <li>● Damaged muffler</li> <li>● Broken or damaged exhaust hanger brackets</li> <li>● Damaged catalytic converter</li> <li>● Cracked exhaust manifold</li> <li>● Loose or damaged heat shields</li> </ul>

4. Verify that the exhaust system is installed correctly, with clamps correctly located and tightened to specification.
5. If the fault is not visually evident, determine the symptom. GO to [Symptom Chart - Exhaust System](#) or GO to [Symptom Chart - NVH](#).

### Symptom Chart — Exhaust System

#### Symptom Chart — Exhaust System

Condition	Possible Sources	Action
<ul style="list-style-type: none"> <li>● Vehicle has low or no power — vehicle performance complaint</li> </ul>	<ul style="list-style-type: none"> <li>● Exhaust pipe pinched or crushed</li> <li>● Damaged catalytic converter</li> <li>● Loose obstruction in exhaust</li>   <li>● Restricted exhaust (possible frozen condensate in muffler)</li> </ul>	<ul style="list-style-type: none"> <li>● INSPECT the exhaust components for damage. REPAIR or INSTALL new components as necessary. TEST the system for normal operation. If the concern is still present, REFER to the Powertrain Control/Emissions Diagnosis (PC/ED) manual.</li> <li>● CHECK drain holes for debris. PARK the vehicle inside to thaw. TEST the vehicle for normal operation. If the concern is still present, REFER to the Powertrain Control/Emissions Diagnosis (PC/ED) manual.</li> </ul>
<ul style="list-style-type: none"> <li>● Burning smell — usually occurs at idle, with possible traces</li> </ul>	<ul style="list-style-type: none"> <li>● Foreign material caught in exhaust system</li> <li>● Missing heat shields</li> </ul>	<ul style="list-style-type: none"> <li>● INSPECT the exhaust system for debris or missing heat shields. REPAIR or INSTALL new components as necessary. TEST the</li> </ul>

of smoke		system for normal operation after the repair.
<ul style="list-style-type: none"> <li>Odor — described as a sulfur or rotten egg smell</li> </ul>	<ul style="list-style-type: none"> <li>Catalytic converter</li> <li>Excessive sulfur content in fuel</li> <li>Rich fuel conditions</li> <li>Misfire conditions</li> </ul>	<ul style="list-style-type: none"> <li>At times, a slight sulfur smell is normal for catalytic converters. The cause is the sulfur content in the gasoline being used. ADVISE the customer no repair is required.</li> <li>REFER to the Powertrain Control/Emissions Diagnosis (PC/ED) manual.</li> </ul>
<ul style="list-style-type: none"> <li>Visible rust on surface of exhaust pipes</li> </ul>	<ul style="list-style-type: none"> <li>Catalytic converter/exhaust system</li> </ul>	<ul style="list-style-type: none"> <li>Surface rust is a characteristic of materials used on exhaust systems. Exposure to heat or road salt may result in surface rust. INSPECT for perforations. If there are no perforations, the condition is normal.</li> </ul>

### Symptom Chart — NVH

### Symptom Chart — NVH

**NOTE:** NVH symptoms should be identified using the diagnostic tools that are available. For a list of these tools, an explanation of their uses and a glossary of common terms, refer to [Section 100-04](#). Since it is possible any one of multiple systems may be the cause of a symptom, it may be necessary to use a process of elimination type of diagnostic approach to pinpoint the responsible system. If this is not the causal system for the symptom, refer back to [Section 100-04](#) for the next likely system and continue diagnosis.

Condition	Possible Sources	Action
<ul style="list-style-type: none"> <li>Rattle, squeaks or buzz type noise — from the bottom of the vehicle</li> </ul>	<ul style="list-style-type: none"> <li>Loose or damaged heat shield</li> <li>Loose or damaged exhaust isolators</li> <li>Damaged exhaust isolator hanger bracket</li> <li>Loose or damaged</li> </ul>	<ul style="list-style-type: none"> <li>INSPECT the exhaust system for loose or missing heat shields or foreign material trapped between the heat shields and the exhaust system components. If any heat shields are loose, INSTALL worm gear clamp 7L5Z-5A231-AA and TIGHTEN to 7 Nm (62 lb-in). If the heat shields are missing, INSTALL new heat shields or exhaust system components as necessary. If a rattle, noise or buzz condition persists, INSTALL a new heat shield or component as necessary. TEST the system for normal operation after the repair.</li> <li>VERIFY that the exhaust isolators are correctly installed. INSPECT the exhaust isolators for wear or damage. INSTALL new isolators as necessary. TEST the system for normal operation after the repair.</li> <li>INSPECT the exhaust system components for damage or broken hangers. INSTALL new components as necessary. CHECK for loose or damaged exhaust hanger brackets or fasteners. TIGHTEN the bolts to specification or INSTALL new components as necessary. TEST the system for normal operation after the repair.</li> <li>MOVE the exhaust system to</li> </ul>

	<p>catalytic converter or muffler</p> <ul style="list-style-type: none"> <li>Exhaust grounded to chassis</li> </ul>	<p>simulate the bouncing action of the vehicle, checking for exhaust-to-body contact while moving the exhaust system. Using a rubber mallet, TAP on the exhaust components to duplicate the noise concern. Lightly TAP on the muffler, then the catalytic converter. DETERMINE if there are loose or broken baffles in the muffler or a loose or broken element in the catalytic converter. REPAIR or INSTALL new components as necessary. TEST the system for normal operation after the repair.</p> <ul style="list-style-type: none"> <li>INSPECT for signs of exhaust components-to-body contact. If necessary, CARRY OUT the <a href="#">Exhaust System Alignment</a> in this section.</li> </ul>
<ul style="list-style-type: none"> <li>Drone or clunk type noise — from the bottom of the vehicle</li> </ul>	<ul style="list-style-type: none"> <li>Loose or damaged exhaust isolators</li> <li>Exhaust grounded to chassis</li> </ul>	<ul style="list-style-type: none"> <li>INSPECT the exhaust isolators for wear or damage. INSTALL new isolators as necessary. TEST the system for normal operation after the repair.</li> <li>INSPECT for signs of exhaust components-to-body contact. If necessary, CARRY OUT the <a href="#">Exhaust System Alignment</a> in this section.</li> </ul>
<ul style="list-style-type: none"> <li>Whistles, boom, hum or ticking type noise — noise tends to change as the engine warms. The noises are often accompanied by exhaust fumes</li> </ul>	<ul style="list-style-type: none"> <li>Exhaust system leak</li> <li>Catalytic converter</li> <li>Exhaust muffler/resonator drain hole enlarged due to corrosion</li> </ul>	<ul style="list-style-type: none"> <li>INSPECT the entire exhaust system for leaks. CHECK for punctures, loose or damaged clamps/fasteners, gaskets, sensors or broken welds. EXAMINE the chassis for grayish-white or black exhaust soot, which indicates exhaust leakage at that point. To magnify a small leak, have an assistant hold a rag over the tail pipe outlet while listening for a leak. REPAIR or INSTALL new components as necessary. TEST the system for normal operation after the repair.</li> <li>MOVE the exhaust system to simulate the bouncing action of the vehicle, checking for exhaust-to-body contact while moving the exhaust system. Using a rubber mallet, TAP on the exhaust components to duplicate the noise concern. Lightly TAP on the muffler and the catalytic converter. DETERMINE if there are loose or broken baffles in the muffler, or a loose or broken element in the catalytic converter. REPAIR or INSTALL new components as necessary. TEST the system for normal operation after the repair.</li> <li>CONFIRM the drain holes are the noise source. INSTALL new components as necessary. TEST the system for normal operation after the repair.</li> </ul>
<ul style="list-style-type: none"> <li>Hissing or rushing noise — high frequency sound.</li> </ul>	<ul style="list-style-type: none"> <li>Exhaust system. Exhaust flow through pipes</li> </ul>	<ul style="list-style-type: none"> <li>CHECK the exhaust system for leaks. Using a rubber mallet, TAP on the exhaust components to duplicate</li> </ul>

Vehicle performance is unaffected		the noise concern. Lightly TAP on the muffler and the catalytic converter. DETERMINE if there are loose or broken baffles in the muffler, or a loose or broken element in the catalytic converter. REPAIR or INSTALL new components as necessary. TEST the system for normal operation after the repair.
<ul style="list-style-type: none"> <li>Pinging noise — occurs when exhaust system is hot, engine turned off</li> </ul>	<ul style="list-style-type: none"> <li>Catalytic converter/exhaust system</li> </ul>	<ul style="list-style-type: none"> <li>Cool down pinging is a result of the exhaust system expanding and contracting during heating and cooling. This is a normal condition.</li> </ul>
<ul style="list-style-type: none"> <li>Vibration — occurs at idle and at low speeds. Also accompanied by a clunk or buzz type noise</li> </ul>	<ul style="list-style-type: none"> <li>Loose or damaged exhaust isolator</li> <li>Loose or damaged exhaust isolator hanger brackets</li> <li>Damper broken or out of position</li> <li>Exhaust system grounded to chassis</li> </ul>	<ul style="list-style-type: none"> <li>INSPECT the exhaust isolators for wear or damage. INSTALL new isolators as necessary. TEST the system for normal operation after the repair.</li> <li>INSPECT the exhaust isolator hanger brackets for wear or damage. INSTALL or REPAIR as necessary. TEST the system for normal operation after the repair.</li> <li>CHECK for the correct damper orientation in this section. RELOCATE to the correct position and tighten the nuts to specification. INSPECT for missing or damaged damper. INSTALL new components as necessary. TEST the system for normal operation after the repair.</li> <li>CARRY OUT the <a href="#">Exhaust System Alignment</a> in this section.</li> </ul>
<ul style="list-style-type: none"> <li>Engine drumming noise — normally accompanied by vibration</li> </ul>	<ul style="list-style-type: none"> <li>Damaged or misaligned exhaust system</li> </ul>	<ul style="list-style-type: none"> <li>INSPECT the exhaust system for loose or damaged fasteners, Torca® clamps or isolators. CARRY OUT the <a href="#">Exhaust System Alignment</a> in this section.</li> </ul>
<ul style="list-style-type: none"> <li>Sputter type noise — noise worse when cold, lessens or disappears when the vehicle is at operating temperature</li> </ul>	<ul style="list-style-type: none"> <li>Damaged or worn exhaust system</li> </ul>	<ul style="list-style-type: none"> <li>INSPECT the exhaust system for leaks or damage. REPAIR as necessary. TEST the system for normal operation after the repair.</li> </ul>
<ul style="list-style-type: none"> <li>Thumping noise — from the bottom of the vehicle, worse at acceleration</li> </ul>	<ul style="list-style-type: none"> <li>Misaligned exhaust system</li> </ul>	<ul style="list-style-type: none"> <li>CHECK the exhaust system to chassis clearance. CHECK the exhaust system isolators for damage. REPAIR as necessary. TEST the system for normal operation after the repair.</li> </ul>
<ul style="list-style-type: none"> <li>Engine vibration — is felt with increases and decreases in engine rpm</li> </ul>	<ul style="list-style-type: none"> <li>Strain on exhaust system isolators</li> </ul>	<ul style="list-style-type: none"> <li>CARRY OUT the <a href="#">Exhaust System Alignment</a> in this section. REPAIR as necessary. TEST the system for normal operation after the repair.</li> </ul>
<ul style="list-style-type: none"> <li>Drumming noise — occurs inside the vehicle during</li> </ul>	<ul style="list-style-type: none"> <li>Exhaust system vibration excites the body resonances</li> </ul>	<ul style="list-style-type: none"> <li><a href="#">GO to Pinpoint Test A</a> .</li> </ul>

idle or high idle, hot or cold. Very low-frequency drumming is very rpm dependent	inducing interior noise	
---	-------------------------	--

## Pinpoint Test

### PINPOINT TEST A: DRUMMING NOISE

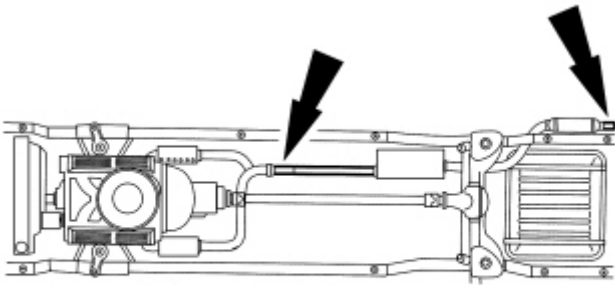
Test Step	Result / Action to Take
<b>A1 CHECK THE EXHAUST SYSTEM</b>	
<ul style="list-style-type: none"> <li>● Start the engine.</li> <li>● Increase the engine rpm until the noise is the loudest. Note the engine rpm.</li> <li>● Ignition OFF.</li> <li>● Add approximately 9 kg (20 lb) of weight to the exhaust system. First place the weight at the tail pipe and test, then at the front pipe.</li> </ul>  <p>DF1768-A</p>	<p><b>Yes</b> REFER to <a href="#">Exhaust System Alignment</a> in this section. TEST the system for normal operation.</p> <p><b>No</b> CONDUCT a diagnosis on other suspect systems. REFER to <a href="#">Section 100-04</a>.</p>
<ul style="list-style-type: none"> <li>● Start the engine.</li> <li>● Increase the engine rpm and listen for the drumming noise. Note the engine rpm if the noise occurs.</li> <li>● Ignition OFF.</li> <li>● Remove the weight from the exhaust system.</li> <li>● <b>Is the noise/vibration reduced or eliminated, or does the noise/vibration occur at a different rpm?</b></li> </ul>	

